

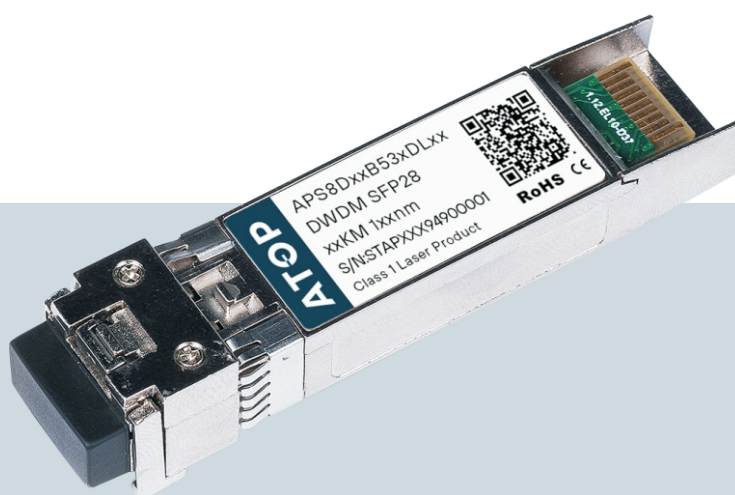

SFP28 DWDM Transceiver

APS8DxxB53xDL10



SFP28 DWDM Transceiver

APS8DxxB53xDL10

ATOP's APS8DxxB53xDL10 is C-band DWDM SFP28 module for duplex optical data communications support up to 25.78Gb/s . The high performance cooled EML transmitter and high sensitivity and low noise receiver provide superior performance for 25G Ethernet and CPRI applications at up to 10km links . It is with the SFP+ 20-pin connector to allow hot plug capability. and digital diagnostic functions are available via an I²C.

Product Features

- ✓ Duplex LC connector
- ✓ Hot-pluggable SFP28 footprint
- ✓ C-band cooled EML laser
- ✓ RoHS compliant and Lead Free
- ✓ Distance up to 10km on 9/125um SMF
- ✓ Metal enclosure for lower EMI
- ✓ Power dissipation<2.3W
- ✓ Commercial and Industrial operating temperature optional

Applications

- ✓ CPRI Option 10
- ✓ 25G Ethernet



Product Selection

Part Number	Operating Case temperature	DDMI
APS8DxxB53CDL10	Commercial(0~70°C)	Yes
APS8DxxB53EDL10	Extend(-20~85°C)	Yes
APS8DxxB53IDL10	Industrial (-40~85°C)	Yes

Product Channel Selection

Product Code	ITU channel	Frequency	Center Wavelength(nm)
APS8D60B53xDL10	60	196.0	1529.55
APS8D59B53xDL10	59	195.9	1530.33
APS8D58B53xDL10	58	195.8	1531.12
APS8D57B53xDL10	57	195.7	1531.90
APS8D56B53xDL10	56	195.6	1532.68
APS8D55B53xDL10	55	195.5	1533.47
APS8D54B53xDL10	54	195.4	1534.25
APS8D53B53xDL10	53	195.3	1535.04
APS8D52B53xDL10	52	195.2	1535.82
APS8D51B53xDL10	51	195.1	1536.61
APS8D50B53xDL10	50	195.0	1537.40
APS8D49B53xDL10	49	194.9	1538.19
APS8D48B53xDL10	48	194.8	1538.98
APS8D47B53xDL10	47	194.7	1539.77
APS8D46B53xDL10	46	194.6	1540.56
APS8D45B53xDL10	45	194.5	1541.35
APS8D44B53xDL10	44	194.4	1542.14
APS8D43B53xDL10	43	194.3	1542.94
APS8D42B53xDL10	42	194.2	1543.73
APS8D41B53xDL10	41	194.1	1544.53
APS8D40B53xDL10	40	194.0	1545.32
APS8D39B53xDL10	39	193.9	1546.12
APS8D38B53xDL10	38	193.8	1546.92
APS8D37B53xDL10	37	193.7	1547.72
APS8D36B53xDL10	36	193.6	1548.51
APS8D35B53xDL10	35	193.5	1549.32
APS8D34B53xDL10	34	193.4	1550.12

Product Channel Selection

Product Code	ITU channel	Frequency	Center Wavelength(nm)
APS8D33B53xDL10	33	193.3	1550.92
APS8D32B53xDL10	32	193.2	1551.72
APS8D31B53xDL10	31	193.1	1552.52
APS8D30B53xDL10	30	193.0	1553.33
APS8D29B53xDL10	29	192.9	1554.13
APS8D28B53xDL10	28	192.8	1554.94
APS8D27B53xDL10	27	192.7	1555.75
APS8D26B53xDL10	26	192.6	1556.55
APS8D25B53xDL10	25	192.5	1557.36
APS8D24B53xDL10	24	192.4	1558.17
APS8D23B53xDL10	23	192.3	1558.98
APS8D22B53xDL10	22	192.2	1559.79
APSPD21B53xDL10	21	192.1	1560.61

Regulatory Compliance

- ESD to the Electrical PINs: compatible with MIL-STD-883 Method 3015
- ESD to the Duplex LC Receptacle: compatible with EN 61000-4-2
- Immunity compatible with EN 61000-4-3
- EMI compatible with FCC Part 15 Class B
- Laser Eye Safety compatible with FDA 21CFR 1040.10 and 1040.11 IEC 60950, IEC60825-1,2
- RoHS compliant with RoHS 2.0(2015/863/EU)-amending.

Pin Descriptions

Pin	Symbol	Name	Ref.
1	VeeT	Transmitter Ground (Common with Receiver Ground)	1
2	TX Fault	Transmitter Fault. LVTTTL-O	2
3	TX Disable	Transmitter Disable. Laser output disabled on high or open. LVTTTL-I	3
4	SDA	2-Wire Serial Interface Data Line(Same as MOD-DEF2 in INF-8074i). LVTTTL-I/O	2
5	SCL	2-Wire Serial Interface Data Line(Same as MOD-DEF2 in INF-8074i). LVTTTL-I	2
6	Mod_ABS	Module Absent, Connect to VeeT or VeeR in Module.	2
7	RS0	Rate Select 0, optionally controls SFP+ module receiver . LVTTTL-I	4
8	LOS	Loss of Signal indication. Logic 0 indicates normal operation. LVTTTL-O	5
9	RS1	Rate Select 1, optionally controls SFP+ module transmitter. LVTTTL-I	4
10	VeeR	Receiver Ground (Common with Transmitter Ground)	1
11	VeeR	Receiver Ground (Common with Transmitter Ground)	1
12	RD-	Receiver Inverted DATA out. AC Coupled. CML-O	
13	RD+	Receiver Non-inverted DATA out. AC Coupled. CML-O	
14	VeeR	Receiver Ground (Common with Transmitter Ground)	1
15	VccR	Receiver Power Supply	6
16	VccT	Transmitter Power Supply	6
17	VeeT	Transmitter Ground (Common with Receiver Ground)	1
18	TD+	Transmitter Non-Inverted DATA in. AC Coupled. CML- I	
19	TD-	Transmitter Inverted DATA in. AC Coupled. CML- I	
20	VeeT	Transmitter Ground (Common with Receiver Ground)	1

Note

1. Circuit ground is internally isolated from chassis ground.
2. TX Fault is an open collector/drain output .Which should be pulled up with a 4.7K – 10K Ohms resistor on the host board if intended for use. Pull up voltage should be between 2.0V to Vcc+0.3V.A high output indicates a transmitter fault caused by either the tx bias current or the tx output power exceeding the preset alarm thresholds. A low output indicates normal operation .In the low state, the output is pulled to <math><0.8V</math>.
3. Laser output disabled on TX Disable >2.0V or open, enabled on TX Disable<math><0.8V</math>.
4. Internally pulled down per SFF-8431 Rev4.1.
5. LOS is open collector output. Should be pulled up with 4.7k – 10kohms on host board to a voltage between 2.0V and 3.6V. Logic 0 indicates normal operation; logic 1 indicates loss of signal.
6. Internally connected.

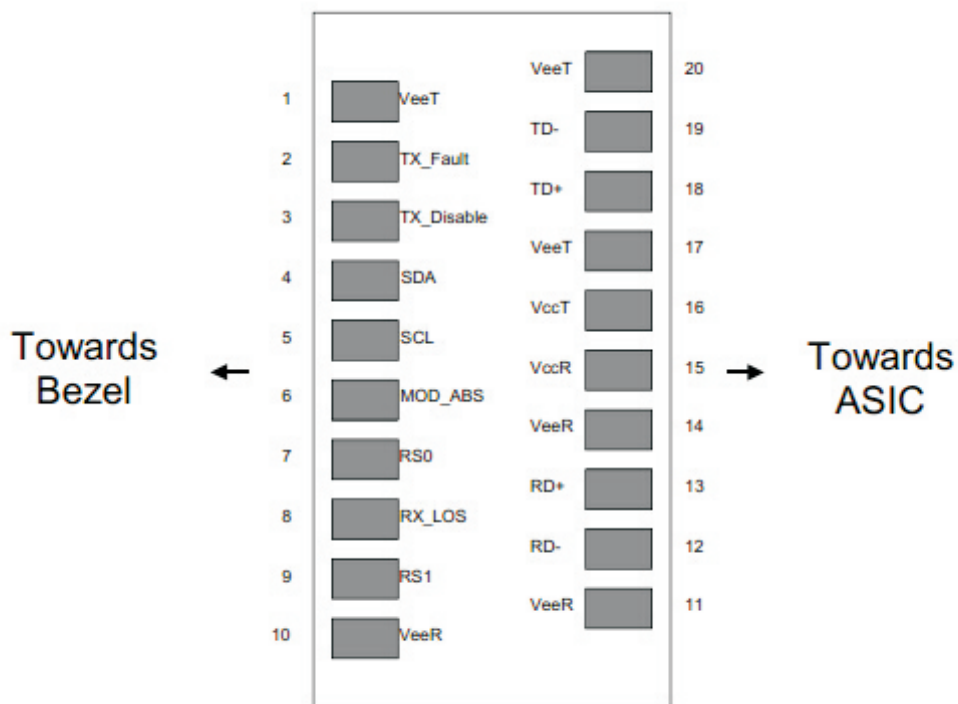

Pin-out of Connector Block on Host Board

Recommend Circuit Schematic

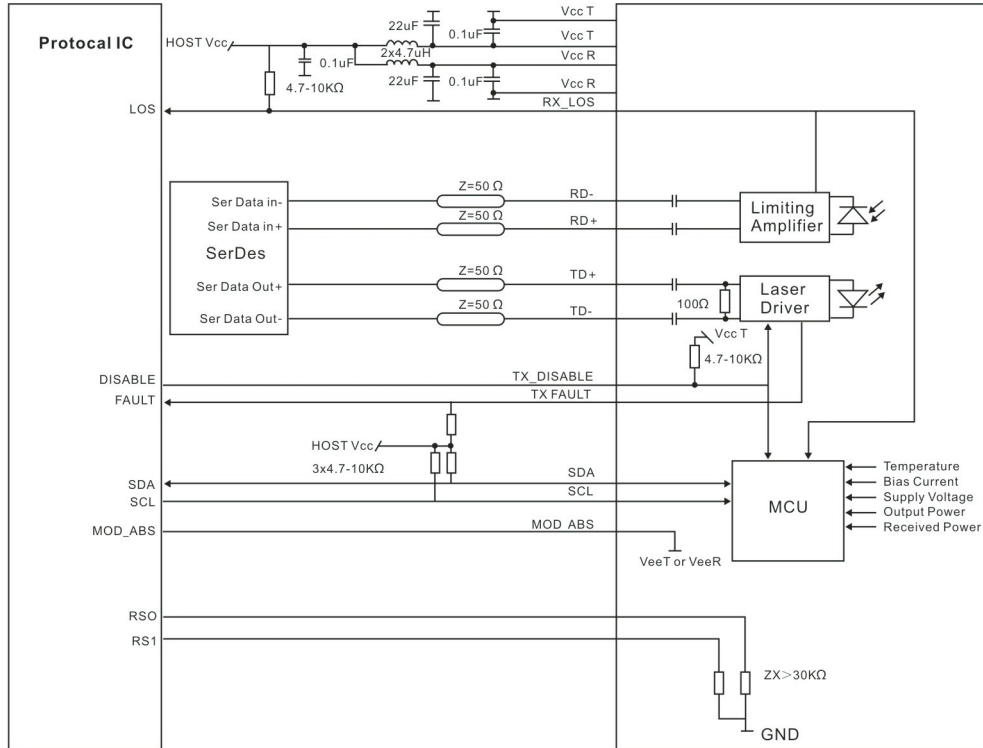

Absolute Maximum Ratings

Parameter	Symbol	Min	Typ	Max	Unit	Ref.
Maximum Supply Voltage	Vcc	-0.5		+4.0	V	
Storage Temperature	TS	-40		+85	°C	
Operating Humidity	RH	0		95	%	

Recommended Operating Conditions

Parameter	Symbol	Min	Typ	Max	Unit	Ref.
Power Supply Voltage	Vcc	3.13	3.30	3.47	V	
Power Supply Current	Icc			660	mA	
Case Operating Temperature	TC	0		+70	°C	
	TE	-20		+85	°C	
	TI	-40		+85	°C	
Data Rate	BR			25.78	Gbps	
9/125um G.652 SMF	Lmax			10	km	

Electrical Characteristics

Parameter	Symbol	Min	Typ	Max	Unit	Ref.
Transmitter						
Input differential impedance	Rin	80	100	120	Ω	1
Differential data input swing	Vin, pp	90		800	mV	
TX Disable-High		Vcc - 0.8		Vcc	V	
TX Disable-Low		Vee		Vee+ 0.8	V	
TX Fault-High		Vcc-0.8		Vcc	V	
TX Fault-Low		Vee		Vee+0.8	V	
Receiver						
Single ended data output swing	Vout, pp	185		425	mV	2
LOS-High		Vcc - 0.8		Vcc	V	
LOS-Low		Vee		Vee+0.8	V	

Notes:

1. AC coupled.
2. Into 100 ohm differential termination.

Optical Characteristics

Parameter	Symbol	Min	Typ	Max	Unit	Ref.
Transmitter						
Output Opt. Power	PO	0		+5	dBm	
Optical Wavelength	λ	As per ITU-T 694.1			nm	
Side-Mode Suppression Ratio	SMSR	35			dB	
Spectral Width(-20dB)	$\Delta\lambda$			1	nm	
Dispersion penalty@15km fiber (BER=10-12)	DP			3.0	dB	
Optical Extinction Ratio	ER	4			dB	
Receiver						
RX Sensitivity @25.78Gb/s	SENS			-13.5	dBm	1
OMA RX Sensitivity @25.78Gb/s	SENS1			-12	dBm	
Receiver Overload @25.78Gb/s	Po	-2			dBm	1
Optical Center Wavelength	λ_C	1520		1600	nm	
LOS De-Assert	LOSD			-15	dBm	
LOS Assert	LOSA	-35			dBm	
LOS Hysteresis		0.5		6	dB	

Notes:

1.Measured with data rate at 25.78Gb/s, ER=7dB, Tc=25degC, BER less than 5E-5 with PRBS 2³¹-1.

Mechanical Specifications

- ATOP's Small Form Factor Pluggable (SFP28) transceivers are compatible with the dimensions defined by the SFP Multi-Sourcing Agreement (MSA), dimensions are in mm.

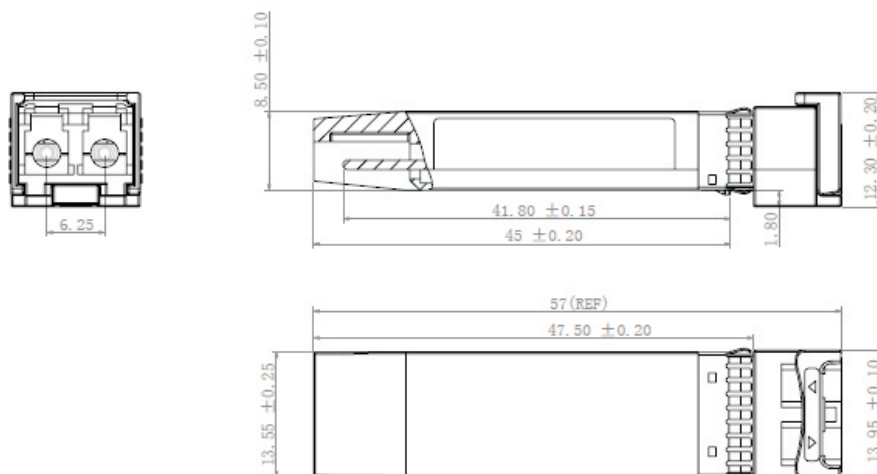

APS8DxxB53xDL10

EEPROM Information

- EEPROM memory map specific data field description is as below:

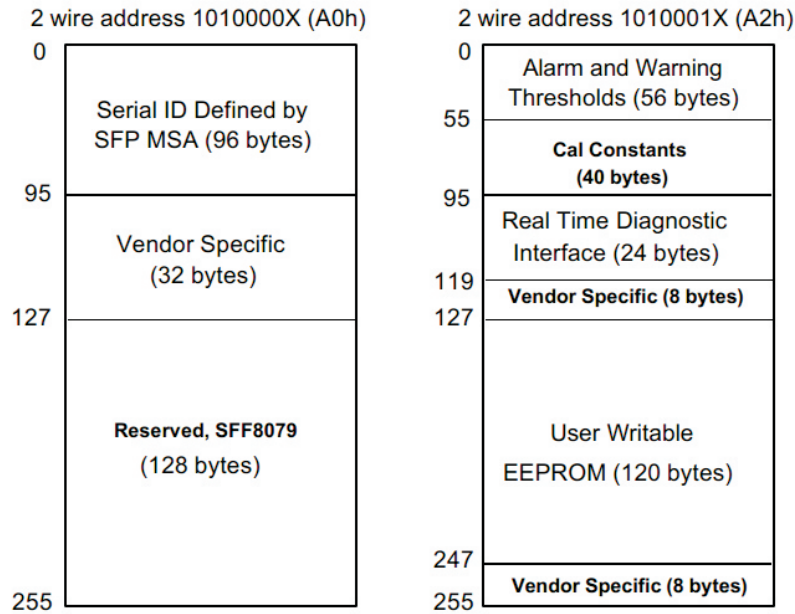

Digital Diagnostic Monitoring Interface

Five transceiver parameter values are monitored. The following table defines the monitored parameter's accuracy.

Parameter	Range	Accuracy	Calibration
Temperature	0 to +70°C(C)	±3°C	Internal
	-20 to +85°C(E)	±3°C	Internal
	-40 to +85°C(I)	±3°C	Internal
Voltage	3.13 to 3.47V	±3%	Internal
Bias Current	0 to 100mA	±10%	Internal
TX Power	0 to +5dBm	±3dB	Internal
RX Power	-15 to -2dBm	±3dB	Internal

Revision History

Revision	Initiated	Reviewed	Approved	DCN	Release Date
Version1.0	TangZhiqiang	Yang Peiyun	DingZheng	New Released.	Feb 11,2019
Version1.1	TangZhiqiang	Yang Peiyun	DingZheng	Update TX power and RX Sensitivity.	May 11,2019
Version1.2	TangZhiqiang	Yang Peiyun	DingZheng	Update RX Sensitivity and LOS	Aug 30,2019
Version1.3	TangZhiqiang	Yang Peiyun	DingZheng	Update the new template	Dec 19, 2019



let's make it personal

atoptechnology.com