

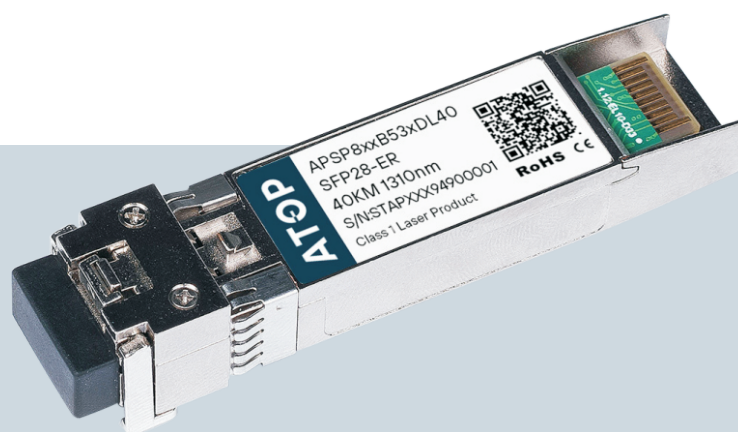

SFP28 ER Transceiver

APSP831B53xDL40



SFP28 ER Transceiver

APSP831B53xDL40

ATOP's APSP831B53xDL40 single-mode transceiver is SFP28 module for duplex optical data communications support up to 28.05Gb/s. It is with the SFP+ 20-pin connector to allow hot plug capability. Digital diagnostic functions are available via an I²C . It has built-in clock and data recovery (CDR). This module is designed for single-mode fiber.

Product Features

- ✓ Duplex LC connector
- ✓ Hot-pluggable SFP28 footprint
- ✓ Operating data rate up to 28.05Gbps
- ✓ Cooled EML laser
- ✓ High performance APD receiver
- ✓ RoHS compliant and Lead Free
- ✓ Distance up to 40km on 9/125um SMF
- ✓ Metal enclosure for lower EMI
- ✓ Power dissipation <2.5W
- ✓ Industrial and Commercial operating temperature optional

Applications

- ✓ CPRI Option 10
- ✓ 25G Ethernet

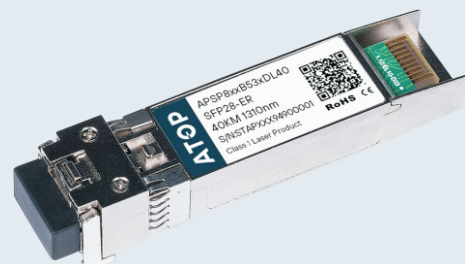

Product Selection

Part Number	Operating Optical Wavelength Center	DDMI	Temperature
APSP831B53CDL40	1310nm	Yes	0~+70°C
APSP831B53IDL40	1310nm	Yes	-40~+85°C

1.Current can provide C-temp products only.

Regulatory Compliance

- ESD to the Electrical PINs: compatible with MIL-STD-883 Method 3015
- ESD to the Duplex LC Receptacle: compatible with EN 61000-4-2
- Immunity compatible with EN 61000-4-3
- EMI compatible with FCC Part 15 Class B
- Laser Eye Safety compatible with FDA 21CFR 1040.10 and 1040.11 IEC 60950, IEC60825-1,2
- RoHS compliant with RoHS 2.0(2015/863/EU)-amending

Pin Descriptions

Pin	Symbol	Name	Ref.
1	VeeT	Transmitter Ground (Common with Receiver Ground)	1
2	TX Fault	Transmitter Fault. LVTTTL-O	2
3	TX Disable	Transmitter Disable. Laser output disabled on high or open. LVTTTL-I	3
4	SDA	2-Wire Serial Interface Data Line (Same as MOD-DEF2 in INF-8074i). LVTTTL-I/O	2
5	SCL	2-Wire Serial Interface Data Line (Same as MOD-DEF2 in INF-8074i). LVTTTL-I	2
6	Mod_ABS	Module Absent, Connect to VeeT or VeeR in Module.	2
7	RS0	Rate Select 0, optionally controls SFP+ module receiver . LVTTTL-I	4
8	LOS	Loss of Signal indication. Logic 0 indicates normal operation. LVTTTL-O	5
9	RS1	Rate Select 1, optionally controls SFP+ module transmitter. LVTTTL-I	4
10	VeeR	Receiver Ground (Common with Transmitter Ground)	1
11	VeeR	Receiver Ground (Common with Transmitter Ground)	1
12	RD-	Receiver Inverted DATA out. AC Coupled. CML-O	
13	RD+	Receiver Non-inverted DATA out. AC Coupled. CML-O	
14	VeeR	Receiver Ground (Common with Transmitter Ground)	1
15	VccR	Receiver Power Supply	6
16	VccT	Transmitter Power Supply	6
17	VeeT	Transmitter Ground (Common with Receiver Ground)	1
18	TD+	Transmitter Non-Inverted DATA in. AC Coupled. CML- I	
19	TD-	Transmitter Inverted DATA in. AC Coupled. CML- I	
20	VeeT	Transmitter Ground (Common with Receiver Ground)	1

Note

1. Circuit ground is internally isolated from chassis ground.
2. TX Fault is an open collector/drain output .Which should be pulled up with a 4.7K – 10K Ohms resistor on the host board if intended for use. Pull up voltage should be between 2.0V to Vcc+0.3V.A high output indicates a transmitter fault caused by either the tx bias current or the tx output power exceeding the preset alarm thresholds. A low output indicates normal operation .In the low state, the output is pulled to <math><0.8V</math>.
3. Laser output disabled on TX Disable >2.0V or open, enabled on TX Disable<math><0.8V</math>.
4. Internally pulled down per SFF-8431 Rev4.1.
5. LOS is open collector output. Should be pulled up with 4.7k – 10kohms on host board to a voltage between 2.0V and 3.6V. Logic 0 indicates normal operation; logic 1 indicates loss of signal.
6. Internally connected.

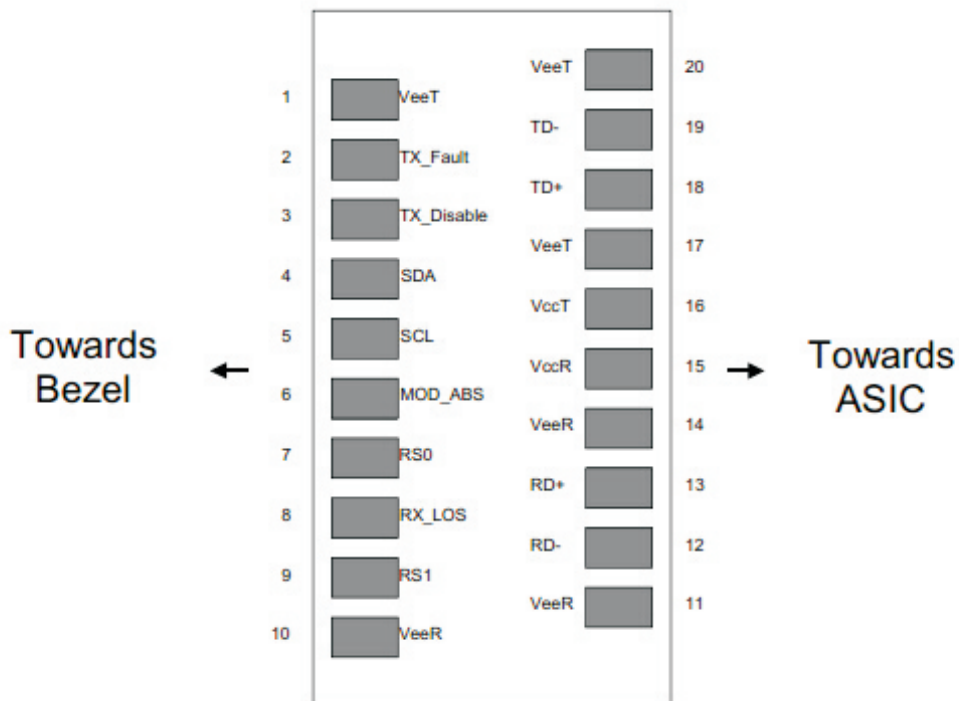

Pin-out of Connector Block on Host Board

Recommend Circuit Schematic

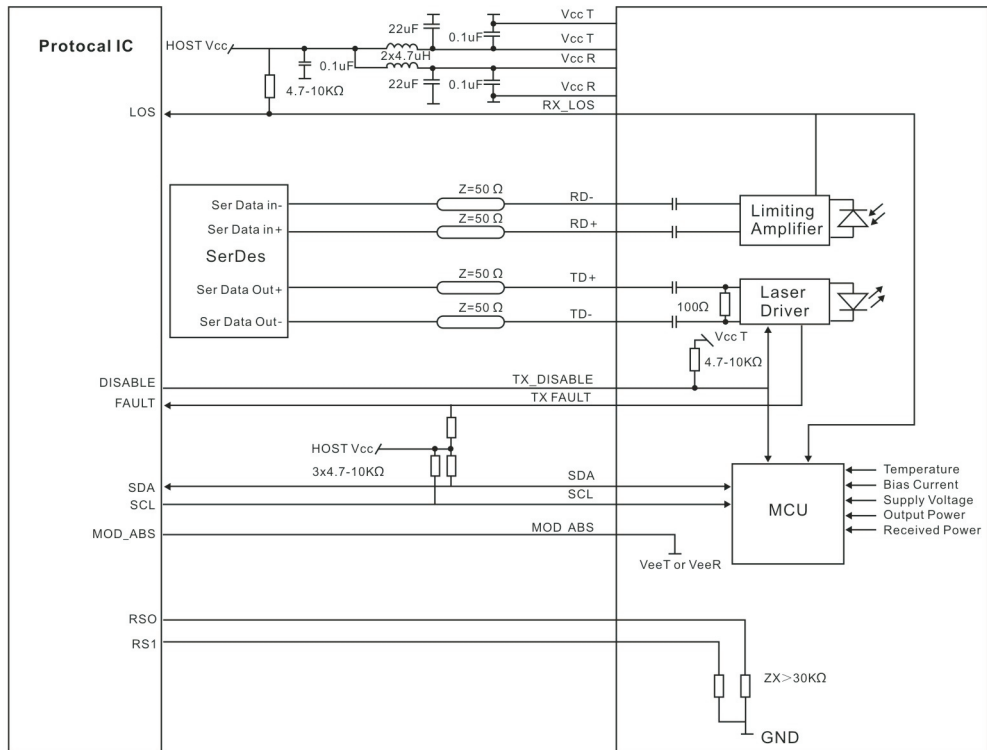

Absolute Maximum Ratings

Parameter	Symbol	Min	Typ	Max	Unit	Ref.
Maximum Supply Voltage	Vcc	-0.5		+4.0	V	
Storage Temperature	TS	-40		+85	°C	
Operating Humidity	RH	0		85	%	

Recommended Operating Conditions

Parameter	Symbol	Min	Typ	Max	Unit	Ref.
Power Supply Voltage	Vcc	3.13	3.30	3.47	V	
Power Supply Current	Icc			550	mA	Commercial
				660	mA	Industrial(TBD)
Case Operating Temperature	TC	0		+70	°C	Commercial
				+85	°C	Industrial(TBD)
Data Rate	BR			28.05	Gbps	
9/125um G.652 SMF	Lmax			40	km	

Electrical Characteristics

Parameter	Symbol	Min	Typ	Max	Unit	Ref.
Transmitter						
Input differential impedance	Rin	80	100	120	Ω	1
Differential data input swing	Vin, pp	90		800	mV	
TX Disable-High		Vcc - 0.8		Vcc	V	
TX Disable-Low		Vee		Vee + 0.8	V	
TX Fault-High		Vcc - 0.8		Vcc	V	
TX Fault-Low		Vee		Vee + 0.8	V	
Receiver						
Single ended data output swing	Vout, pp	185		425	mV	2
LOS-High		Vcc - 0.8		Vcc	V	
LOS-Low		Vee		Vee + 0.8	V	

Notes:

1. AC coupled.
2. Into 100 ohm differential termination.

Optical Characteristics

Parameter	Symbol	Min	Typ	Max	Unit	Ref.
Transmitter						
Output Opt. Power	PO	-3		+6	dBm	
Output Opt. Power_OMA	PO _{OMA}	0		+6	dBm	
Optical Wavelength	λ	1295		1310	nm	
Side-Mode Suppression Ratio	SMSR	30			dB	
Spectral Width(-20dB)	$\Delta\lambda$			1	nm	
Optical Extinction Ratio	ER	4			dB	
Receiver						
RX Sensitivity @25.78Gb/s	SENS			-21	dBm	1
RX Sensitivity_OMA @25.78Gb/s	SENS _{OMA}			-19	dBm	1
Receiver Overload @25.78Gb/s	Po	-4			dBm	1
Receiver Overload_OMA @25.78Gb/s	Po _{OMA}	-4			dBm	1
Optical Center Wavelength	λ_C	1295		1325	nm	
LOS De-Assert	LOSD			-22	dBm	
LOS Assert	LOSA	-35			dBm	
LOS Hysteresis		0.5		6	dB	

Notes:

1.Measured with data rate at 25.78Gb/s, ER=7dB, Tc=25degC, BER less than 5E-5 with PRBS 2³¹-1.

Mechanical Specifications

- ATOP's Small Form Factor Pluggable (SFP28) transceivers are compatible with the dimensions defined by the SFP Multi-Sourcing Agreement (MSA) , dimensions are in mm.

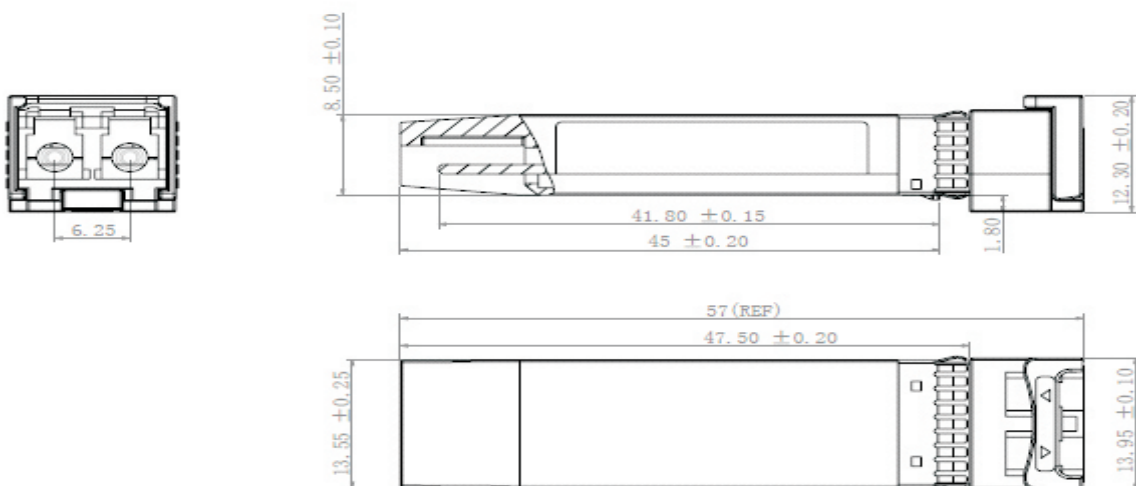

APSP831B53xDL40

EEPROM Information

- EEPROM memory map specific data field description is as below:

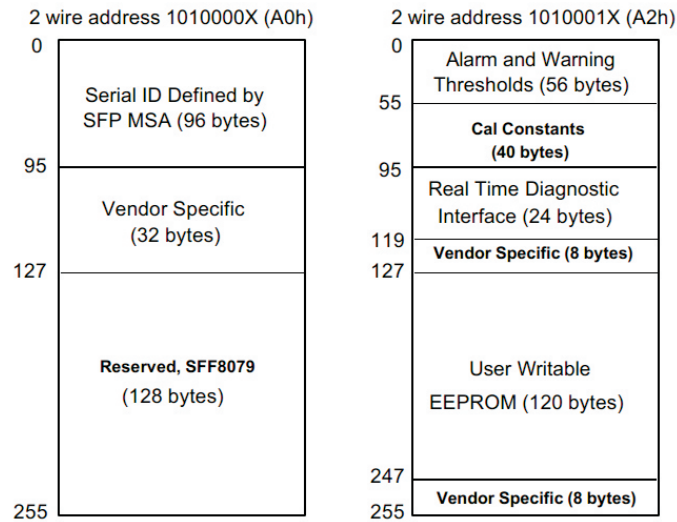

Digital Diagnostic Monitoring Interface

Five transceiver parameter values are monitored. The following table defines the monitored parameter's accuracy.

Parameter	Range	Accuracy	Calibration
Temperature	0 to +70°C (C)	±3°C	Internal
	-40 to +85°C (I)		
Voltage	2.97 to 3.63V	±3%	Internal
Bias Current	0 to 80mA	±10%	Internal
TX Power	-3 to +6dBm	±3dB	Internal
RX Power	-21 to -4dBm	±3dB	Internal

Revision History

Revision	Initiated	Reviewed	Approved	DCN	Release Date
Version1.0	YangPeiyun	TangZhiqiang	DingZheng	New Released.	Dec 27, 2018
Version1.1	TangZhiqiang	YangPeiyun	DingZheng	Update the new template	June 13, 2020



let's make it personal

www.atoptechnology.com