



QSFP28 to 2xSFP28 Passive Cable

APCP05-QSCxxx-yy



QSFP28 to 2xSFP28 Passive Cable

APCP05-QSCxxx-yy

The 100G QSFP28 passive cable based on 4X25G or 4X28G structure, can satisfy the next generation of 100G switches, servers, routers and other product applications. QSFP28 cable module adopts optimized design to reduce crosstalk and insertion loss. It has excellent signal integrity and fully meets the next generation 100G Ethernet and InfiniBand EDR standards. SFP28 is based on the same shape of SFP+ and supports 25G Ethernet standard. It can provide 25GB/s error-free transmission, and can be applied to high density 25G Ethernet switch and network interface to promote server connection in data center. It uses the popular SFP + package form, provides a more cost-effective solution for enterprises to upgrade 10G Ethernet connection. 100G QSFP28 to 2x25G SFP28 supports the interconnection of two interface devices with a single channel transmission rate of 25Gbps.

Product Features

- ✓ Compliant with SFF-8636, SFF-8402
- ✓ Compliant with IEEE802.3bj
- ✓ Supporting I2C two-wire serial interface for easy control
- ✓ Supporting hot insertion
- ✓ Low crosstalk
- ✓ low power consumption
- ✓ ROHS compliant

Applications

- ✓ 10G/40G/100g Ethernet
- ✓ InfiniBand: SDR, DDR, QDR, FDR, EDR
- ✓ Switch
- ✓ Router
- ✓ Data Center, Cloud Server



Product Selection

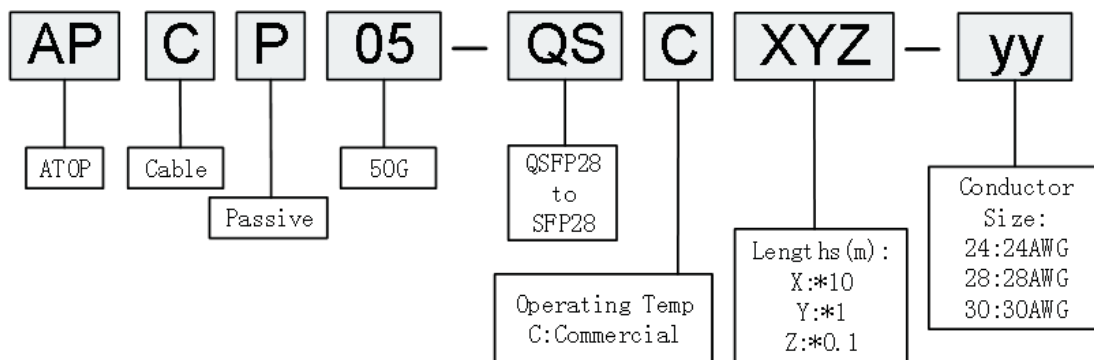

Part Number	Lengths	Conductor Size	Note
APCP05-QSC005-yy	0.5m	26/28/30 AWG	1
APCP05-QSC010-yy	1m	26/28/30 AWG	1
APCP05-QSC015-yy	1.5m	26/28/30 AWG	1
APCP05-QSC020-yy	2m	26/28/30 AWG	1
APCP05-QSC025-yy	2.5m	26/28/30 AWG	1
APCP05-QSC030-yy	3m	26/28/30 AWG	1
APCP05-QSC050-yy	5m	26/28/30 AWG	1

Note:

1, yy=30,28,26, present wire size AWG

Pin Descriptions

QSFP28 End

Pin	Symbol	Name	Ref.
1	GND	Ground	
2	Tx2n	Transmitter Inverted Data Input, CML-I	
3	Tx2p	Transmitter Non-Inverted Data output, CML-I	
4	GND	Ground	
5	Tx4n	Transmitter Inverted Data Input, CML-I	
6	Tx4p	Transmitter Non-Inverted Data output, CML-I	
7	GND	GND	
8	ModSelL	<p>The ModSelL is an input pin. When held low by the host, the module responds to 2-wire serial communication commands. The ModSelL allows the use of multiple QSFP+ modules on a single 2-wire interface bus. When the ModSelL is "High", the module shall not respond to or acknowledge any 2-wire interface communication from the host. ModSelL signal input node must be biased to the "High" state in the module</p>	
9	ResetL	<p>The ResetL pin must be pulled to Vcc in the QSFP+ module. A low level on the ResetL pin for longer than the minimum pulse length (t_Reset_init) initiates a complete module reset, returning all user module settings to their default state. Module Reset Assert Time (t_init) starts on the rising edge after the low level on the ResetL pin is released.</p>	
10	VccRx	+ 3.3V Power Supply Receiver	
11	SCL	2-Wire Serial Interface Clock	
12	SDA	2-Wire Serial Interface Data	
13	GND	GND	
14	Rx3p	Receiver Non-Inverted Data Output, CML-O	
15	Rx3n	Receiver Inverted Data Output, CML-O	

16	GND	GND
17	Rx1p	Receiver Non-Inverted Data Output, CML-O
18	Rx1n	Receiver Inverted Data Output, CML-O
19	GND	Ground
20	GND	Ground
21	Rx2n	Receiver Inverted Data Output, CML-O
22	Rx2p	Receiver Non-Inverted Data Output, CML-O
23	GND	Ground
24	Rx4n	Receiver Inverted Data Output, CML-O
25	Rx4p	Receiver Non-Inverted Data Output, CML-O
26	GND	Ground
27	ModPrsL	Module Present, connect to GND
28	IntL	The IntL pin is an open collector output and must be pulled to host supply voltage on the host board. The INTL pin is de-asserted "High" after completion of reset, when byte 2 bit 0 (Data Not Ready) is read with a value of '0' and the flag field is read.
29	VccTx	+3.3 V Power Supply transmitter
30	Vcc1	+3.3 V Power Supply
31	LPMODE	The LPMODE pin shall be pulled up to Vcc in the QSFP+ module. This function is affected by the LPMODE pin and the combination of the Power_over-ride and Power_set software control bits (Address A0h, byte 93 bits 0,1).
32	GND	Ground
33	Tx3p	Transmitter Non-Inverted Data Input, CML-I
34	Tx3n	Transmitter Inverted Data Output, CML-I
35	GND	Ground
36	Tx1p	Transmitter Non-Inverted Data Input, CML-I
37	Tx1n	Transmitter Inverted Data Output, CML-I
38	GND	Ground

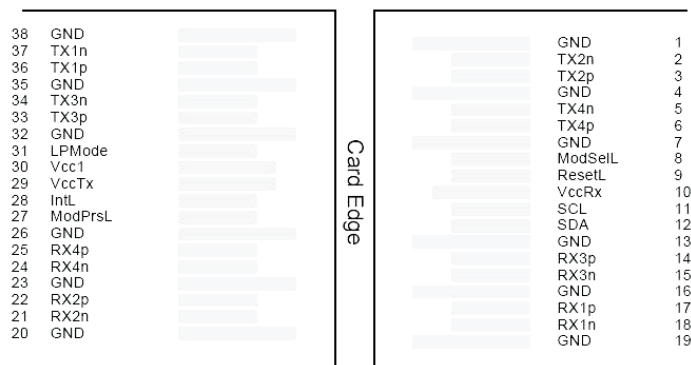

Top Side Viewed from Top Bottom Side Viewed from Bottom

Pin-out of Connector Block on Host Board

SFP28 End

Pin	Symbol	Name	Ref.
1	VeeT	Transmitter Ground (Common with Receiver Ground)	
2	TX Fault	Transmitter Fault. LVTTTL-O	
3	TX Disable	Transmitter Disable. Laser output disabled on high or open. LVTTTL-I	
4	SDA	2-Wire Serial Interface Data Line (Same as MOD-DEF2 in INF-8074i). LVTTTL-I/O	
5	SCL	2-Wire Serial Interface Data Line (Same as MOD-DEF2 in INF-8074i). LVTTTL-I	
6	Mod_ABS	Module Absent, Connect to VeeT or VeeR in Module.	
7	RS0	Rate Select 0, optionally controls SFP+ module receiver LVTTTL-I	
8	LOS	Loss of Signal indication. Logic 0 indicates normal operation. LVTTTL-O	
9	RS1	Rate Select 1, optionally controls SFP+ module transmitter. LVTTTL-I	
10	VeeR	Receiver Ground (Common with Transmitter Ground)	
11	VeeR	Receiver Ground (Common with Transmitter Ground)	
12	RD-	Receiver Inverted DATA out. AC Coupled. CML-O	
13	RD+	Receiver Non-inverted DATA out. AC Coupled. CML-O	
14	VeeR	Receiver Ground (Common with Transmitter Ground)	
15	VccR	Receiver Power Supply	
16	VccT	Transmitter Power Supply	
17	VeeT	Transmitter Ground (Common with Receiver Ground)	
18	TD+	Transmitter Non-Inverted DATA in. AC Coupled. CML-I	
19	TD-	Transmitter Inverted DATA in. AC Coupled. CML-I	
20	VeeT	Transmitter Ground (Common with Receiver Ground)	

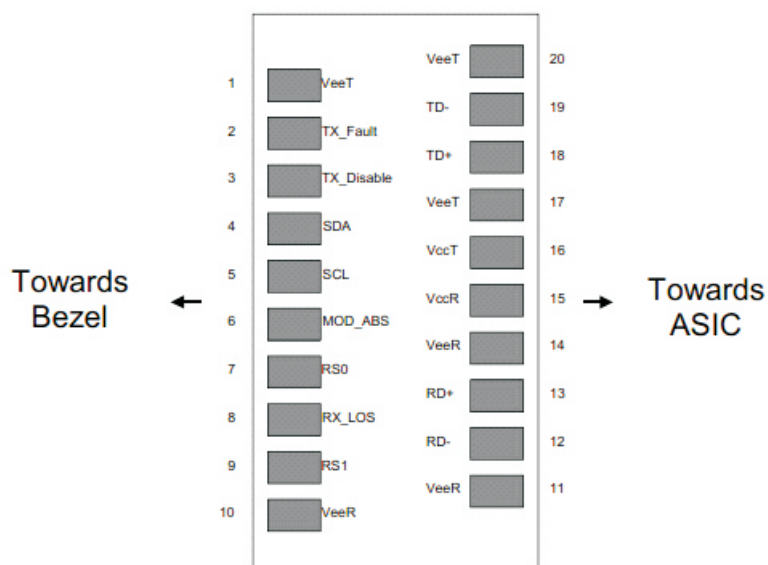

Pin-out of Connector Block on Host Board

Signal Integrity

ITEM	REQUIREMENT	TEST CONDITION																																				
Cable Impedance	105+5/-10Ω																																					
Differential Impedance	Paddle Card Impedance Cable Termination Impedance	100±10Ω 100±15Ω																																				
		Rise time of 25ps (20% - 80%).																																				
[Differential (Input/Output) Return loss SDD11/SDD22]	$\text{Return_loss}(f) \geq \begin{cases} 16.5-2\sqrt{f} & 0.05 \leq f < 4.1 \\ 10.66-14\log_{10}(f/5.5) & 4.1 \leq f \leq 19 \end{cases}$ <p>Where f is the frequency in GHz Return_loss(f) is the return loss at frequency f</p>	10MHz ≤ f ≤ 19GHz																																				
[Differential to common-mode (Input/Output) Return loss SCD11/SCD22]	$\text{Return_loss}(f) \geq \begin{cases} 22-(20/25.78)f & 0.01 \leq f < 12.89 \\ 15-(6/25.78)f & 12.89 \leq f \leq 19 \end{cases}$ <p>Where f is the frequency in GHz Return_loss(f) is the Differential to common-mode return loss at frequency f</p>	10MHz ≤ f ≤ 19GHz																																				
Common-mode to Common-mode (Input/Output) Return loss SCC11/SCC22	$\text{Return_loss}(f) \geq 2\text{dB} \quad 0.2 \leq f \leq 19$ <p>Where f is the frequency in GHz Return_loss(f) is the common-mode to common-mode return loss at frequency f</p>	10MHz ≤ f ≤ 19GHz																																				
(Differential Insertion Loss Max. For TPa to TPb Excluding Test fixture)																																						
Differential Insertion Loss (SDD21 Max.)	<table border="1"> <thead> <tr> <th>AWG \ F</th> <th>1.25GHz</th> <th>2.5GHz</th> <th>5.0GHz</th> <th>7.0GHz</th> <th>10GHz</th> <th>12.89GHz</th> </tr> </thead> <tbody> <tr> <td>30(1m)Max.</td> <td>4.5dB</td> <td>5.4dB</td> <td>6.3dB</td> <td>7.5dB</td> <td>8.5dB</td> <td>10.5dB</td> </tr> <tr> <td>30/28(3m)Max.</td> <td>7.5dB</td> <td>9.5dB</td> <td>12.2dB</td> <td>14.8dB</td> <td>18.0dB</td> <td>21.5dB</td> </tr> <tr> <td>26(3m)Max.</td> <td>5.7dB</td> <td>7.2dB</td> <td>9.9dB</td> <td>11.9dB</td> <td>14.1dB</td> <td>16.5dB</td> </tr> <tr> <td>26/25(5m)Max.</td> <td>7.8dB</td> <td>10.0dB</td> <td>13.5dB</td> <td>16.0dB</td> <td>19.0dB</td> <td>22.0dB</td> </tr> </tbody> </table>	AWG \ F	1.25GHz	2.5GHz	5.0GHz	7.0GHz	10GHz	12.89GHz	30(1m)Max.	4.5dB	5.4dB	6.3dB	7.5dB	8.5dB	10.5dB	30/28(3m)Max.	7.5dB	9.5dB	12.2dB	14.8dB	18.0dB	21.5dB	26(3m)Max.	5.7dB	7.2dB	9.9dB	11.9dB	14.1dB	16.5dB	26/25(5m)Max.	7.8dB	10.0dB	13.5dB	16.0dB	19.0dB	22.0dB		
	AWG \ F	1.25GHz	2.5GHz	5.0GHz	7.0GHz	10GHz	12.89GHz																															
	30(1m)Max.	4.5dB	5.4dB	6.3dB	7.5dB	8.5dB	10.5dB																															
	30/28(3m)Max.	7.5dB	9.5dB	12.2dB	14.8dB	18.0dB	21.5dB																															
26(3m)Max.	5.7dB	7.2dB	9.9dB	11.9dB	14.1dB	16.5dB																																
26/25(5m)Max.	7.8dB	10.0dB	13.5dB	16.0dB	19.0dB	22.0dB																																
			10MHz ≤ f ≤ 19GHz																																			
Differential to common-mode Conversion Loss-Differential Insertion Loss (SCD21-SDD21)	$\text{Conversion_loss}(f) - \text{IL}(f) \geq \begin{cases} 10 & 0.01 \leq f < 12.89 \\ 27-(29/22)f & 12.89 \leq f < 15.7 \\ 6.3 & 15.7 \leq f \leq 19 \end{cases}$ <p>Where f is the frequency in GHz Conversion_loss(f) is the cable assembly differential to common-mode conversion loss IL(f) is the cable assembly insertion loss</p>	10MHz ≤ f ≤ 19GHz																																				
MDNEXT(multiple disturber near-end crosstalk)	≥26dB @12.89GHz	10MHz ≤ f ≤ 19GHz																																				

Other Electrical Performance

ITEM	REQUIREMENT	TEST CONDITION
Low Level Contact Resistance	70milliohms Max. From initial.	EIA-364-23:Apply a maximum voltage of 20mV And a current of 100 mA.
Insulation Resistance	10Mohm(Min.)	EIA364-21:AC 300V 1 minute
Dielectric Withstanding Voltage	NO disruptive discharge.	EIA-364-20:Apply a voltageof 300VDC for 1 minute between adjacent terminals And between adjacent terminals and ground.

Environment Performance

ITEM	REQUIREMENT	TEST CONDITION
Operating Temp. Range	0°C to +70°C	Cable operating temperature range.
Storage Temp. Range (in packed condition)	-40°C to +80°C	Cable storage temperature range in packed condition.
Thermal Cycling Non-Powered	No evidence of physical damage	EIA-364-32D, Method A, -25 to 90C, 100 cycles, 15 min. dwells
Salt Spraying	48 hours salt spraying after shell corrosive area less than 5%.	EIA-364-26
Mixed Flowing Gas	Pass electrical tests per 3.1 after stressing. (For connector only)	EIA-364-35 Class II, 14 days.
Temp. Life	No evidence of physical damage	EIA-364-17C w/ RH, Damp heat 90°C at 85% RH for 500 hours then return to ambient
Cable Cold Bend	4H, No evidence of physical damage	Condition: -20°C ±2°C , mandrel diameter is 6 times the cable diameter.

Mechanical and Physical Characteristics

ITEM	REQUIREMENT	TEST CONDITION
Vibration	Pass electrical tests per 3.1 after stressing.	Clamp & vibrate per EIA-364-28E, TC-VII, test condition letter – D, 15 minutes in X, Y & Z axis.
Cable Flex	No evidence of physical damage	Flex cable 180° for 20 cycles ($\pm 90^\circ$ from nominal position) at 12 cycles per minute with a 1.0kg load applied to the cable jacket. Flex in the boot area 90° in each direction from vertical. Per EIA-364-41C
Cable Plug Retention in Cage	90N Min. No evidence of physical damage	Pull on cable jacket approximately 1 ft behind cable plug. No functional damage to cable plug below 90N. Per SFF-8432 Rev 5.0
Cable Retention in Plug	90N Min. No evidence of physical damage	Cable plug is fixtured with the bulk cable hanging vertically. A 90N axial load is applied (gradually) to the cable jacket and held for 1 minute. Per EIA-364-38B
Mechanical Shock	Pass electrical tests Per 3.1 after stressing.	Clamp and shock per EIA-364-27B, TC-G, 3 times in 6 directions, 100g, 6ms.
Cable Plug Insertion	40N Max. (QSFP+) 18N Max. (SFP+)	Per SFF-8432 Rev 5.0
Cable plug Extraction	30N Max. (QSFP28) 12.5N Max. (SFP28)	Measure without the aid of any cage kick-out springs. Place axial load on de-latch to de-latch plug. Per SFF-8432 Rev 5.0
Durability	50 cycles, No evidence of physical damage	EIA-364-09, perform plug & unplug cycles: Plug and receptacle mate rate: 250times/hour. 50times for module (CONNECTOR TO PCB)

Mechanical Specifications

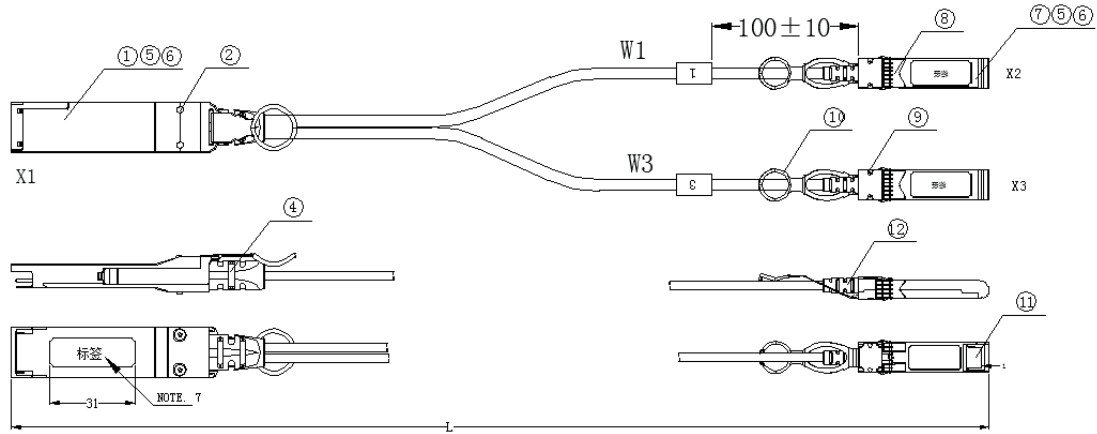

wire	Starting signal	Starting	End	End signal
W1	RX1+	X1. 17	X2. 18	TX1+
	RX1-	X1. 18	X2. 19	TX1-
	GND	X1. 19	X2. 20	GND
	TX1+	X1. 36	X2. 13	RX1+
	TX1-	X1. 37	X2. 12	RX1-
	GND	X1. 38	X2. 14	GND

wire	Starting signal	Starting	End	End signal
W3	RX3+	X1. 14	X3. 18	TX3+
	RX3-	X1. 15	X3. 19	TX3-
	GND	X1. 16	X3. 20	GND
	TX3+	X1. 33	X3. 13	RX3+
	TX3-	X1. 34	X3. 12	RX3-
	GND	X1. 35	X4. 14	GND

Package diagram

<=2m: 200mm*300mm
>2m: 300mm*350mm

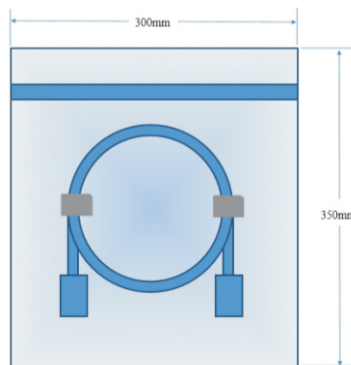

Revision History

Revision	Initiated	Reviewed	Approved	DCN	Release Date
Version1.0	Tangzhiqiang	Li Tao	Ding zheng	New Released.	Nov 19, 2019



let's make it personal

atoptechnology.com